



# **Automatic Vehicle Identification**

---

*Identity Zip*  
**900 MHz Transceiver**  
**Pre-Installation Questionnaire**

**sirit**  
*Identifying solutions*

---

# Pre-Installation Questionnaire

---

## Table of Contents

1.0. Cable Type Selection.....	2
2.0. Connector Types and Tools.....	2
3.0. Mounting Brackets.....	2
4.0. Transponders.....	3
5.0. Relays.....	4
6.0. Readers and Lane Configuration.....	4
7.0. Equipment Placement.....	4
8.0. Gates.....	5
9.0. Access Control System.....	5
10.0. Lane Configuration.....	6
11.0. Miscellaneous.....	6
12.0. Site Examples.....	7
13.0. Island Design Sketch.....	9
14.0. Site License – Customer Disclaimer 6/11/02.....	10

## List of Figures

Figure 3.1 – <i>IDentity Zip</i> Mounting Options.....	3
Figure 12.1 – Single lane set ups consisting of an entry and exit antenna.....	7
Figure 12.2 – Installation Examples.....	8
Figure 13.1 – Island Design Sketch.....	9

## List of Tables

Table 6.1 – Reader and Lane Configuration.....	4
Table 7.1 – Equipment Placement.....	5
Table 8.1 – Gate Manufacturer and Model.....	5

---

## Pre-Installation Questionnaire

---

*The purpose of this document is to provide the customer with a means of selecting required installation equipment as well as a site planning reference guide. Filling out this questionnaire will ensure a prepared and timely installation of the Sirit IDentity Zip reader system. For any technical support questions please contact Sirit at 1-877-492-0101.*

### **1.0. Cable Type Selection**

The *IDentity Zip* system requires the use of Belden 9913, RG-8/U 50 Ohm cable with a maximum length of 75 feet.

### **2.0. Connectors Types and Tools**

- 2.1. For Belden 9913 cable, installers will need to convert from 9913 to a mini UHF connector at the reader end. SIRIT can provide cable converter kit as an option by quoting part # IDZIP-CABLECON.
- 2.2. Each antenna requires (4) Amphenol 82-202-1006 connectors. The installer will have to provide these connectors or SIRIT can provide these as an option by quoting part # IDZIP-CONN-9913.
- 2.3. Installers must use the proper crimping tool to install the above connectors. You can purchase this item locally (Amphenol CTL-5) or SIRIT can provide this as an option by quoting part # IDZIP-CRIMP.

*Special care must be taken when installing the above connectors. The details on how to install the above connectors properly can be found in SIRIT's Hardware Installation manual starting on pg. 37. **Failure to use the right connectors/crimpers or procedure may result in decreased read range or no read at all.***

### **3.0. Mounting Brackets**

- 3.1. SIRIT supplies one universal-mounting bracket per antenna; however other brackets may be used.
- 3.2. For pole or wall mount antennas, SIRIT has an optional Pole/wall mount bracket part # IDZIP-ANT-WMB.
- 3.3. For ceiling mount antennas, SIRIT has an optional ceiling mount bracket part # IDZIP-ANT-CMB.

## Pre-Installation Questionnaire

 <p style="text-align: center;"><b>IDZIP-ANT-01</b></p>		<p style="text-align: center;"><b>Antenna with Universal Mounting Bracket (As Sold)</b></p>
 <p style="text-align: center;"><b>IDZIP-ANT-CMB</b></p>	 <p style="text-align: center;">Mounting Bar (Not Supplied)</p>	<p style="text-align: center;"><b>Universal Ceiling Mount Bracket</b></p>
 <p style="text-align: center;"><b>IDZIP-ANT-CMB+WMB</b></p>		<p style="text-align: center;"><b>Optional Ceiling Mount Method</b></p>
 <p style="text-align: center;"><b>IDZIP-ANT-WMB</b></p>	 <p style="text-align: center;">SCREWLOK Pipe Clamps (Not Supplied)</p>	<p style="text-align: center;"><b>Universal Pole / Wall Mount Bracket</b></p>
 <p style="text-align: center;">LAG SHIELDS (Not Supplied)      LAG SCREWS (Not Supplied)</p>		<p style="text-align: center;"><b>Optional Universal Pole / Wall Mount Bracket</b></p>
<p style="text-align: center;"><b>IDZIP-ANT-WMB</b></p>		

Figure 3.1 – *Identity Zip* Mounting Options

### 4.0. Transponders

Sirit offers two (2) types of vehicle mounted transponders:

#### 4.1. Zip Transponder part # IDZIP-TAG-01

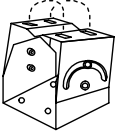
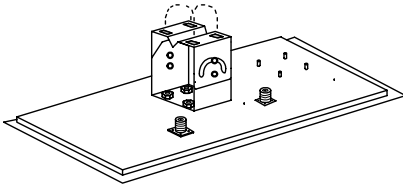
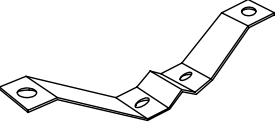
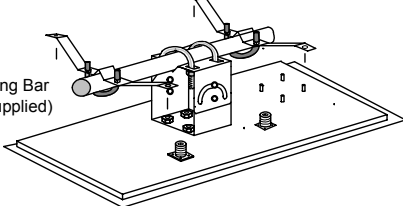
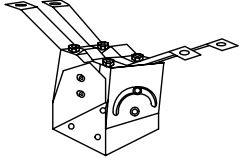
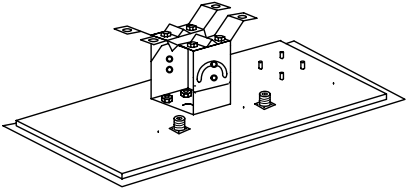
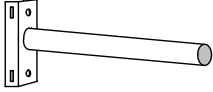
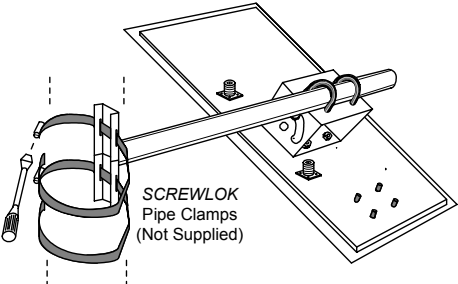
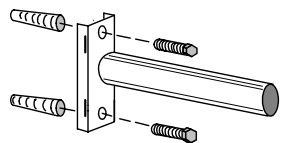
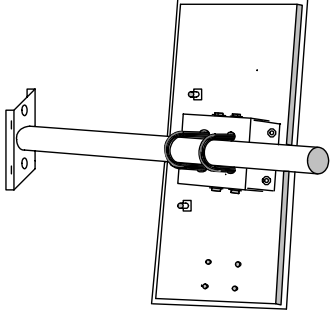
---

## Pre-Installation Questionnaire

---

- 4.2. Three percent of vehicles may require license plate transponders as they may contain metal oxide in their windshields. External Mount (License Plate) part # IDZIP-TAG-LP

*Customers should ensure that the IDentity Zip transponders read in the desired windshield location prior to affixing to the glass.*

### 5.0. Relays

- 5.1. If relays are required, Sirit can provide them as an option. Please contact Sirit if necessary.

### 6.0. Readers and Lane Configuration

- 6.1. Please complete the table below for each IDentity Zip Reader system.

Table 6.1 – Reader and Lane Configuration

Reader #	# Entrance Lanes	# Exit Lanes	# Reversible Lanes	# Antennas
1				
2				
3				
4				

### 7.0. Equipment Placement

- 7.1. If installing two or more readers or antennas please provide a diagram showing the planned placement and the distance separating each unit. Also indicate if there is conduit available for low voltage wiring between each of the readers. Use the attached island diagram as a template if applicable.
- 7.2. Show the cabling distance between each reader and the respective Antennas. Also check the respective box for the mounting location of each antenna.

## Pre-Installation Questionnaire

Table 7.1 – Equipment Placement

Cabling Distance between Reader and Antenna								
Reader #	Ft./M	Ant. #1	Ft./M	Ant. #2	Ft./M	Ant. #3	Ft./M	Ant. #4
<b>1</b>		<input type="checkbox"/> Ceiling <input type="checkbox"/> Pole <input type="checkbox"/> Wall		<input type="checkbox"/> Ceiling <input type="checkbox"/> Pole <input type="checkbox"/> Wall		<input type="checkbox"/> Ceiling <input type="checkbox"/> Pole <input type="checkbox"/> Wall		<input type="checkbox"/> Ceiling <input type="checkbox"/> Pole <input type="checkbox"/> Wall
<b>2</b>		<input type="checkbox"/> Ceiling <input type="checkbox"/> Pole <input type="checkbox"/> Wall		<input type="checkbox"/> Ceiling <input type="checkbox"/> Pole <input type="checkbox"/> Wall		<input type="checkbox"/> Ceiling <input type="checkbox"/> Pole <input type="checkbox"/> Wall		<input type="checkbox"/> Ceiling <input type="checkbox"/> Pole <input type="checkbox"/> Wall
<b>3</b>		<input type="checkbox"/> Ceiling <input type="checkbox"/> Pole <input type="checkbox"/> Wall		<input type="checkbox"/> Ceiling <input type="checkbox"/> Pole <input type="checkbox"/> Wall		<input type="checkbox"/> Ceiling <input type="checkbox"/> Pole <input type="checkbox"/> Wall		<input type="checkbox"/> Ceiling <input type="checkbox"/> Pole <input type="checkbox"/> Wall
<b>4</b>		<input type="checkbox"/> Ceiling <input type="checkbox"/> Pole <input type="checkbox"/> Wall		<input type="checkbox"/> Ceiling <input type="checkbox"/> Pole <input type="checkbox"/> Wall		<input type="checkbox"/> Ceiling <input type="checkbox"/> Pole <input type="checkbox"/> Wall		<input type="checkbox"/> Ceiling <input type="checkbox"/> Pole <input type="checkbox"/> Wall

### 8.0. Gates

8.1. List manufacturer and models of all gates.

Table 8.1 – Gate Manufacturer and Model

Manufacturer Name	Model	Memory Buffer Circuitry (Y/N)

8.2. Will there be traffic backups during peak periods? (Yes / No) \_\_\_\_\_

### 9.0. Access Control System

9.1. Will the Sirit reader interface with a third party access control system (host)? (Yes/No) \_\_\_\_\_

9.2. Whose access control system will you be using (e.g. McGann, Federal APD, WPS, Sentex)? \_\_\_\_\_

9.3. How will the IDentity Zip readers communicate with the access control system (e.g., RS-232, Wiegand)? \_\_\_\_\_

9.4. Will the IDentity Zip reader be directly activating a gate (i.e., relay)? (Yes/No) \_\_\_\_\_

9.5. Will the IDentity Zip reader be directly activating a light? (Yes/No) \_\_\_\_\_

---

## Pre-Installation Questionnaire

---

### 10.0. Lane Configuration

- 10.1. What is the desired read range (i.e., how far away from the antenna do you want to read the transponder)? \_\_\_\_\_
- 10.2. In your sequence of lane logic, when do you want the Tag to be read?
- a) Upon entering the read zone \_\_\_\_\_
  - b) After triggering a ground loop \_\_\_\_\_
- 10.3. When do you want the Tag read to be sent from the reader to the host/lane controller? \_\_\_\_\_  
(example: after the vehicle is over the presence loop; when the gate is down or moving down)
- 10.4. Are there any conditions (e.g. gate up) where your system will not accept an AVI read? \_\_\_\_\_
- 10.5 How far is the antenna from the reader? \_\_\_\_\_

### 11.0. Miscellaneous

*Installers will need a laptop computer (with DB-9 serial cable) to set the reader configurations/antenna read distances and for routine maintenance tasks such as tag list updates. If a laptop is not available, Sirit can preset the reader parameters prior to shipping. The parameters will be set based on the site description details provided by the installer.*

- 11.1. Do you have a laptop at the site location to set up and configure the IDentity ZIP firmware? (Yes/No) \_\_\_\_\_
- 11.2. Will the system interface to overhead garage door openers? (Yes/No) \_\_\_\_\_
- 11.3. Are there any new or existing in ground detector loops? (Yes/No) \_\_\_\_\_
- 11.4. Will the antennas be mounted under a metal canopy? (Yes/No) \_\_\_\_\_
- 11.5. Will users remove the transponders from their cars and carry them, after parking? (Yes/No) \_\_\_\_\_
- 11.6. Are you aware of any radio frequency transmission sources operating in the 912 MHz to 920 MHz range near or at your site? (Yes/No) \_\_\_\_\_
- 11.7. Do you have a digital camera and an e-mail address to send location pictures if required? (Yes/No) \_\_\_\_\_

# Pre-Installation Questionnaire

## 12.0. Site Examples

Figure 12.1 – Single lane set ups consisting of an entry and exit antenna

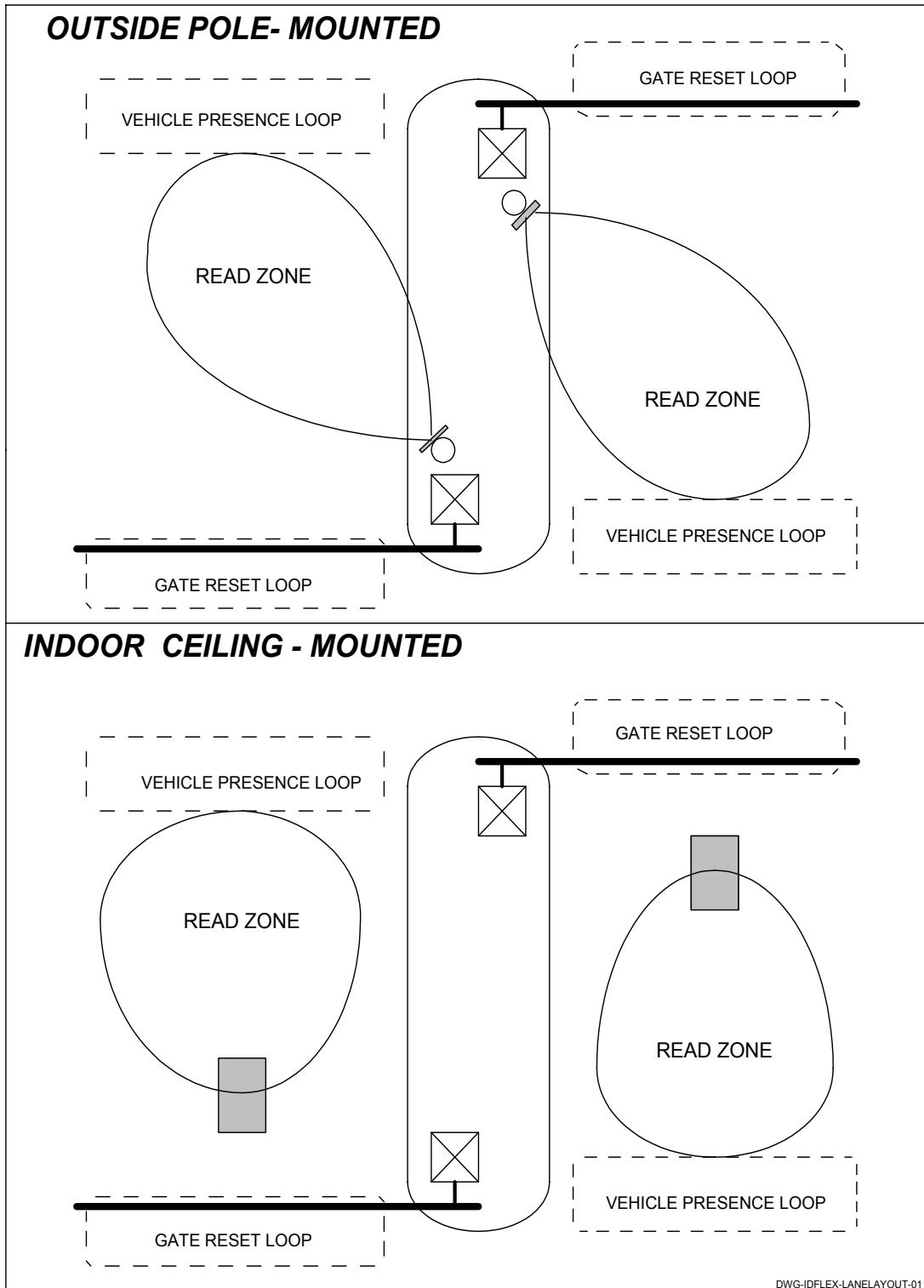

---

## Pre-Installation Questionnaire

---

Figure 12.2 – Installation Examples



---

## Pre-Installation Questionnaire

---

### 13.0. Island Design Sketch

Please fax the attached island diagram with the following to (972) 243-8034 when completed:

- Direction of Travel
- Position of Card Readers
- Position of Gates, Ticket Spitters and Booths
- Dimensions of Island
- Position and Size of any Metal Signs
- Position and Sizes of in-Ground Detector Loops
- Position of Bollards
- Island Location Name
- Position and Orientation of each of each Antenna relative to others

Figure 13.1 – Island Design Sketch

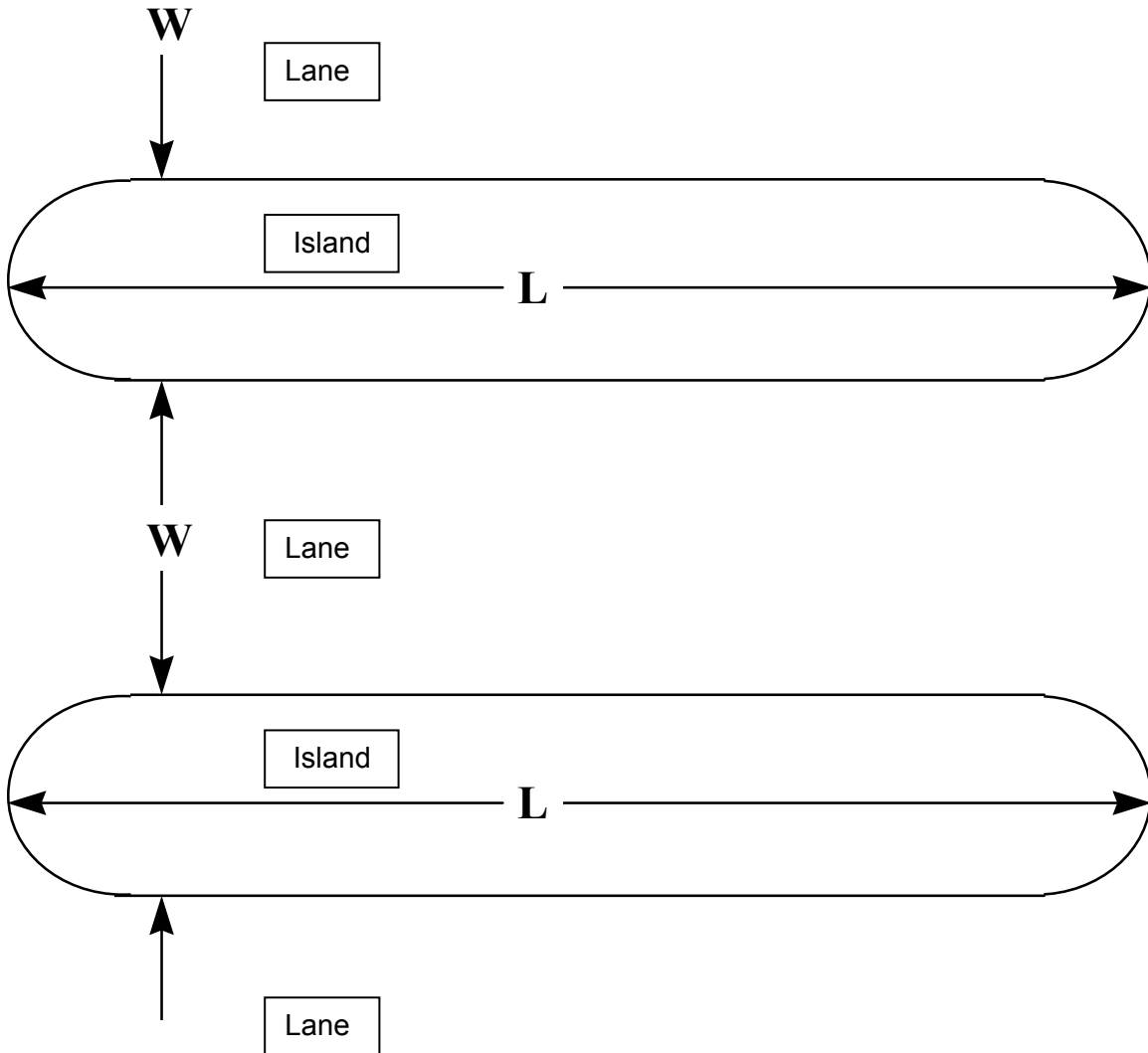

---

## Pre-Installation Questionnaire

---

### **14.0. Site License – Customer Disclaimer6/11/02**

Customer (end user) acknowledges that a site license is required for each IDentity Zip system location. It is the customer's responsibility to file for this site license and submit the appropriate filing payment. SIRIT will assist with the completion of the forms. United States filings require completion and submission of form numbers 159, 601 Main, 601 D, and 601 H to the FCC (Federal Communications Commission). Canadian filings require completion and submission of form number IC2365BB and IC2430BB to Industry Canada.